

GS-B6020

Design

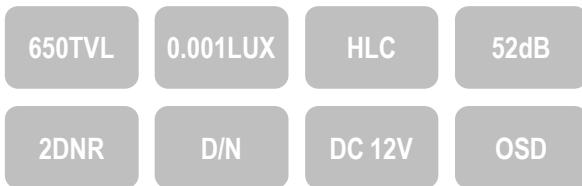

Key Features

- ◆ Standard Box Camera
- ◆ SONY Exview HAD CCD II (ICX672/3AKA)
- ◆ High Resolution 650/700TVL
- ◆ OSD/2D-DNR/BLC/MD/Privacy Masking
- ◆ Style Housing, DC / VD Lens Drive

Dimensions

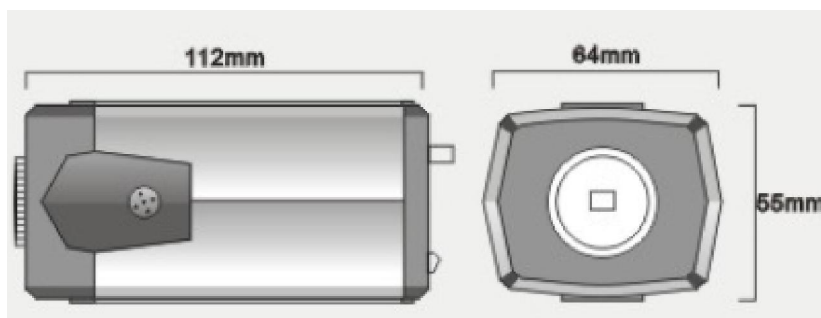

Technical Specifications

MODEL	GS-B6020	
TV System	NTSC	PAL
Effective Pixels	976(H)×494(V)	976(H)×582(V)
Shutter Speed	1/60 to 1/100,000sec.	1/50 to 1/110,000sec.
Image Sensor	1/3" Exview HAD CCD II (ICX672/3AKA)	
DSP Device	Effio-E (CXD4127GG,CXD4816GG)	
Lens Mount	C/CS	
Resolution	Color Mode: 650TVL; B/W Mode:700TVL	
Sync.System	Internal	
S/N Ratio	More than 52dB (AGC off)	
Gain Control	Auto/Manual	
Min.Illumination	0.001LUX /F2.0	
Day/Night	True Day and Night (Auto/ Day / Night / Ext. D&N)	
OSD	Yes	
Gamma Correction	r = 0.45	
White Balance	ATW/User1/User2	
Video Output	1Vp-p, 75W	
Power Supply	DC 12V±10%	
Operating Temp	-10°C~+50°C	
Operating Humidity	95% RH max.	
Dimension	65(W)×55(H)×125(L) mm	
Weight	500g	

Design and specifications are subject to change without notice.