

JVC

PROFESSIONAL

1/3" CCD COLOUR VIDEO CAMERA

TK-C750E

Replacement of TK-C700E
(24V AC)

1/3" CCTV Surveillance Camera with DSP
and High Sensitivity for Use in All Lighting
Conditions

0.28 Super LoLux™
lux

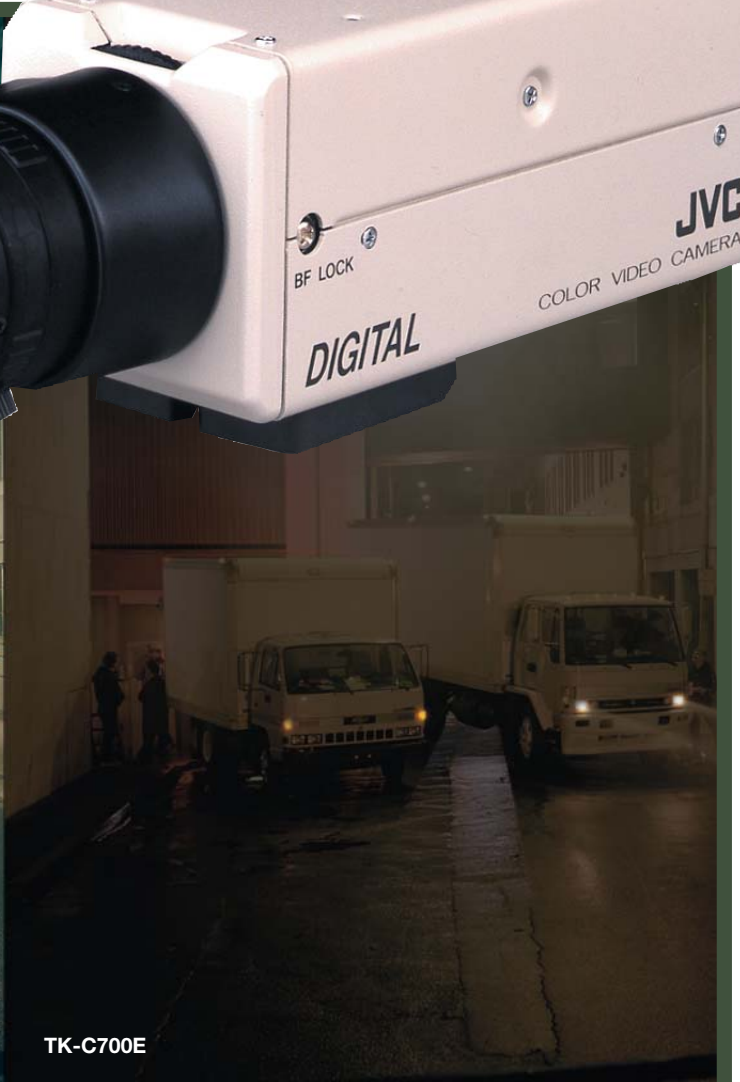

Shown with optional lens

- 1/3-inch IT CCD with 290,000 effective pixels
- Auto White Balance Tracking (ATW) and one-touch Auto White Balance (AWB)
- Auto White Balance adjustment range from 2,300°K to 10,000°K
- Automatic Gain Control (Max. 26 dB)
- S/N ratio 50 dB (AGC off)
- Back-light Compensation
- Automatic Electronic Shutter
- DC iris lens connection
- AC 24V power operation

CCTV surveillance camera with almost full night-shooting capability in a compact, cost-effective package

JVC's high-sensitivity TK-C750E CCTV surveillance camera packs powerful features, including an innovative digital signal processor for Super LoLux (0.28 lux minimum) shooting applications and outstanding colour reproduction, yet delivers them in a package that offers outstanding value and reliability.

■ 1/3-Inch CCD with 290,000 Effective Pixels

JVC's TK-C750E comes with a 1/3-inch Interline Transfer (IT) CCD for accurate colour reproduction, high sensitivity, and crisp pictures with no image lag or distortion.

■ Detail Correction — Horizontal and Vertical: 2H (dual)

JVC's TK-C750E provides exceptional detail — horizontal and vertical — with a 2 H line memory for security imaging applications.

■ Digital Signal Processor (DSP)

JVC's innovative Digital Signal Processor (DSP) automatically adjusts camera parameters to ensure sharp, natural pictures (330 TV lines of horizontal resolution) in near total darkness. It also provides a Super LoLux shooting capability for mission critical surveillance applications.

■ Automatic Gain Control (AGC)

Automatic Gain control (AGC: range from 0 to 26 dB), supported by CCD and DSP functions, automatically adjusts gain to the appropriate value for the ambient lighting conditions.

■ Auto White Balance

Built-in Automatic White Balance Tracking (ATW) and One-touch Auto White Balance (AWB). Auto White Balance is adjusted automatically over the colour temperature range of 2,300°K to 10,000°K. White balance also can be adjusted with one-touch operation for easy camera set-up under various lighting conditions.

■ Signal to Noise (S/N) ratio of 50 dB(AGC off)

The TK-C750E features a signal to noise ratio of 50 dB for sharp pictures with very precise colour reproduction even with the AGC activated.

Controls, Connectors and Indicators



- | | |
|--|------------------------------------|
| 1 BACK FOCUS locking screw | 8 BACK LIGHT COMPENSATION switch |
| 2 BACK FOCUS adjustment and C/CS mount selector ring | 9 AUTO WHITE BALANCE select switch |
| 3 Lens mount (C or CS) | 10 LL/INT select switch |
| 4 Camera mounting bracket | 11 SET button |
| 5 IRIS connector | 12 RESET button |
| 6 LEVEL volume | 13 Power Indication |
| 7 AUTOMATIC ELECTRONIC SHUTTER switch | |

Specifications

Image device	1/3" IT CCD, 500 (H) x 582 (V)
Sync system	Internal, Line Lock (60 Hz regions only)
Scanning frequency	15.625 kHz (H), 50.0 Hz (V)
Horizontal resolution	330 TV lines
Video output	Composite video signal 1 V(p-p), 75 ohms, unbalanced
Video S/N ratio	50 dB (AGC off)
Minimum required illumination	0.28 lux (25%) 0.55 lux (50%)
Automatic electronic shutter	1/50 — 1/100,000 sec.
Lens mount	C/CS mount
Power requirement	AC 24 V (60 Hz)
Power consumption	240 mA
Operating temperature range	-10°C to 50°C 0°C to 40°C (recommended)
Weight	340g

Dimensions

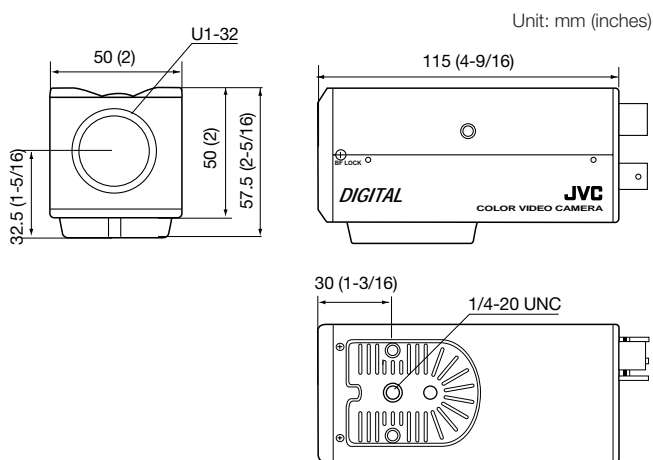

JVC

DISTRIBUTED BY

VICTOR COMPANY OF JAPAN, LIMITED

Design and specifications subject to change without notice.



■ The Hachioji Plant of Victor Company of Japan, Ltd., has received ISO14001 and ISO9001 Certifications under the global standard for environmental management.