

JVC®

The Perfect Experience / —

WIDE DYNAMIC RANGE CAMERA

TK-WD310E

(24V AC / 12V DC)

High Resolution Camera using 14-bit Digital Processing and WDR imaging device to provide crisp, clear images even under adverse backlighting conditions



480 TV Lines



- 1/3" digital image device with Wide Dynamic Range (WDR)
- Innovative 14-bit DSP
- High-speed, automatic 5-level exposure control for each pixel
- 480 TV lines of horizontal resolution
- Programmable camera menu system, operated by selector
- White balance: Automatic, Single-push and Manual
- Sync system: INT and LL, switchable
- 24-character camera title
- DC and Video iris
- Ultra-compact camera body
- 24V AC and 12V DC

Versatile, high-resolution camera with wide dynamic range performance and 14-bit digital processing delivers clear, natural pictures even against bright backlighting.

Especially designed to capture clear, easy-to-view images under poor or unpredictable lighting conditions such as in multi-story car parks and at road junctions, this versatile high-resolution camera features a wide-dynamic-range digital image device that uses sophisticated multi-sampling and a 14-bit DSP which accurately reproduces natural colour tones without any halation (blooming) or smear. Even when the illumination suddenly changes — becoming suddenly brighter or darker, or if the scene includes both bright and dark areas, this camera still captures a clear image that closely resembles what you see with your own eyes.

■ 1/3" WDR digital image device

Featuring a much wider dynamic range than conventional imaging devices, the 1/3" WDR digital image device is able to respond quickly and accurately to high contrast and sudden variations in lighting to deliver high-quality, well-exposed pictures with no smear or blooming. Equally effective in very bright or low-light conditions, this device is capable of shooting at 0.9 lux (at F1.2, 25%, AGC HIGH setting), to ensure quality imaging even of the most dimly lit subjects.

■ Innovative 14-bit DSP

To support the WDR image device, the TK-WD310E incorporates an innovative 14-bit digital signal processing chip that adjusts the brightness level of each individual pixel, so reproducing clear details of not only the foreground subjects but also of the brightly lit background, such as the situation with an entrance camera looking from a foyer into a sunny street. A normal CCD camera could only correctly expose either the background or the foreground, displaying the other as either dark silhouette or burnt-out white, respectively. This means that even when the camera is shooting in locations where there is a very high contrast between light and dark, the captured images will come out looking clear and natural. For example, car headlights can be captured without smear, assuring easy identification of the number plate and so enabling high-quality surveillance.

■ High-speed WDR (Wide Dynamic Range) with automatic 5-level exposure control for each pixel

For smooth, accurate imaging, the wide dynamic range function uses a high-precision multi-sampling system that controls exposure with 5-level sampling of each image pixel within a single frame.

■ 480 TV lines of horizontal resolution

With horizontal resolution of 480 TV lines (typical) and vertical resolution of over 400 lines, this camera captures sharp, clear images that make it an ideal source for high-quality, finely detailed video recordings.

■ Programmable menu with selector operation

A convenient on-screen menu with selector operation is provided for easy adjustment of various system parameters including focus control and camera settings. The factory default settings can be restored easily, if so required.

■ White balance: Automatic (ATW)/single-push (AWB)/manual (MANUAL)

ATW, AWB and MANUAL modes are available. The ATW mode automatically adjusts white balance according to changes in lighting conditions (2,500°K to 10,000°K). The AWB/MANUAL mode automatically or manually adjusts and locks the white balance for specific lighting conditions.

Notes:

1. The WDR function will not operate with AGC or slow shutter mode engaged.
2. The video pictures can become noisy in high extremes of temperature (over 35°C / 95°F), when also the operation of the slow shutter function may become problematic.
3. In very dark conditions the image quality may suffer slight deterioration.
4. Under fluorescent lighting, the colour balance may vary slightly.
5. Fluctuations in the AC mains frequency can cause beat noise, when the camera is in Line-Lock mode.
6. All manufacturer utilizing this technology will experience similar phenomenon.

Rear Panel



Specifications

Image pickup device	1/3" WDR digital image device
Number of effective pixels	380,000 Pixels (720H x 540V)
Synchronization method	Internal, Line Lock
Scanning frequency	(H) 15.625 kHz, (V) 50.0 Hz
Resolution	480 TV lines (H)
Video out	Composite video signal, 1 V (p-p), 75 ohms (BNC)
Video S/N ratio	50 dB (AGC OFF)
Minimum required illumination	0.9 lux (25%, F1.2, AGC HIGH, WDR MODE 2)
Lens mount	CS mount
Power supply	AC 24 V, 50 Hz/60 Hz; DC 12 V
Power consumption	Approx. 400 mA
Ambient temperature	-10°C to 50°C (14°F to 122°F) (operation), 0°C to 35°C (32°F to 90°F) (recommended)
Dimensions (WHD)	50 x 57.5 x 107 mm
Mass	330 g
Accessory supplied	Ferrite core for lens cable

Dimensions

Unit: mm

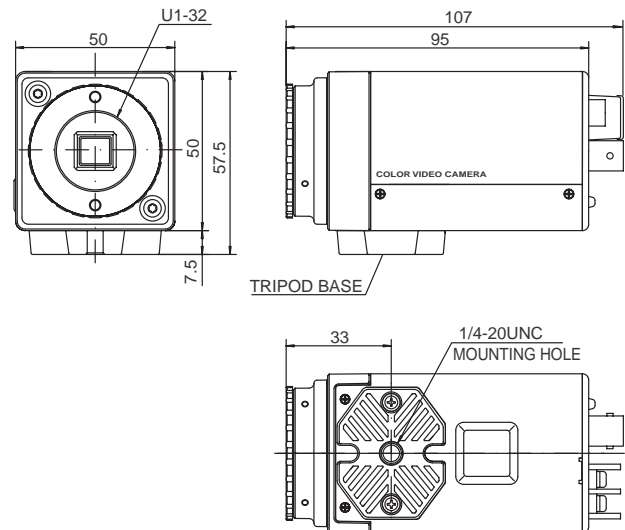

Design and specifications subject to change without notice.

JVC®

DISTRIBUTED BY

Victor Company of Japan, Limited



■ The Hachioji Plant of Victor Company of Japan, Ltd., has received ISO14001 and ISO9001 Certifications under the global standard for environmental management.