

For many years, Sony has offered feature-rich surveillance cameras to users who seek customized solutions for a variety of security applications. Now, Sony unveils two groundbreaking new color video cameras – the SSC-G723 and the SSC-G728 – which add newly developed benefits, customized functions, and operational flexibility to the current SSC Series. What makes the SSC-G723/G728 excellent is that the cameras achieve an super high resolution of 650 TV lines. Also, with DynaView EX technology, they are capable of adjusting tone and properly capturing high-contrast scenes. As a result, they help to provide substantial visual information for security investigations and to streamline your inspection duties.

Offering numerous beneficial features such as Optical Day/Night, Noise Reduction, BLC, Privacy Zone Masking, and Custom Templates, the SSC-G723/G728 is the perfect security camera in various locations such as banks, offices, parking lots, subways, and transportation.



Color Video Camera SSC-G723/SSC-G728

FEATURES

Wide Dynamic Range With DynaViewEX Technology

The SSC-G723/G728 incorporates DynaViewEX technology to capture high-contrast scenes and produce clear images even under less-than-ideal lighting conditions. This means it can capture critical information that may have been missed by other cameras without such technology. DynaViewEX technology consists of three sub-technologies:

- **High-speed double shutter** provides a wider shutter speed range compared to previous technologies so that the cameras can reproduce images with incredibly wide dynamic ranges.
- **iBLC** compensates for the exposure levels in dark scenes to improve the visibility of the subject.
- **Natural synthesizer** plays an important role in minimizing synthesized noise, which occurs when combining two images of different shutter speeds.

Superb Picture Quality With Accurate Color Reproduction

Employing a Super HAD II CCD sensor, the SSC-G723/G728 offers a high horizontal resolution of 650 TV lines and produces amazingly clear and detailed images. Moreover, the cameras achieve a minimum illumination of 0.22 lx; therefore, the image quality under low-lighting conditions is great enough to enable round-the-clock security operations.

Noise Reduction

The SSC-G723/G728 incorporates Adaptive DNR (Digital Noise Reduction) technology, which eliminates noise and motion blur to produce distinct and clear images. Adaptive DNR technology utilizes both an adaptive 2D filter and an adaptive 3D filter according to the AGC value to reduce noise.

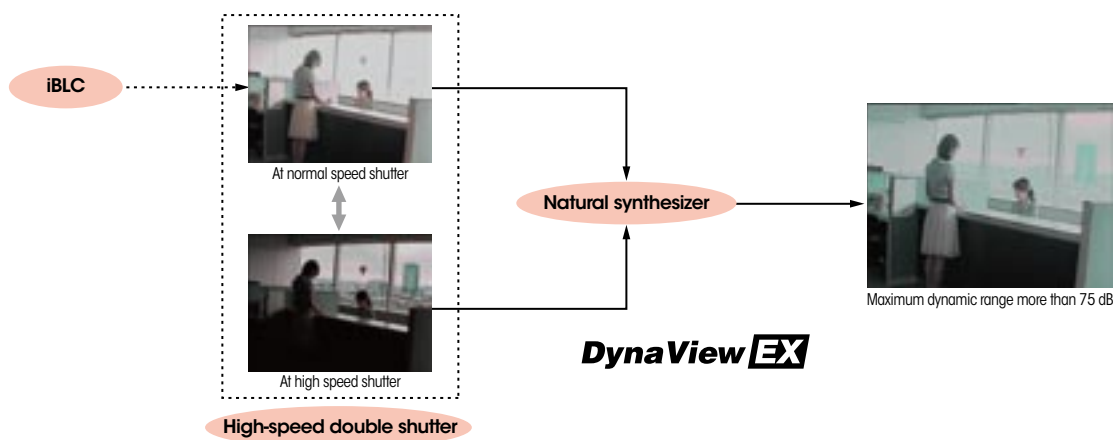

Wider Auto Tracing White Range (ATW)

The ATW function automatically adjusts the camera's white balance to adapt to sudden changes in lighting conditions. The SSC-G723/G728 provides an extremely wide ATW range of 2,000 K to 10,000 K, allowing adjustment-free operation under a variety of lighting conditions.

Back Light Compensation

Unwanted backlighting tends to cause the subject matter of an image to be cast into shadow. The BLC function of these cameras automatically compensates for such undesirable conditions and improves the visibility of the subject.

Custom Template

To achieve quick and easy operation, the SSC-G723/G728 has six custom templates including ENTRANCE, OFFICE, PARKING, SUBWAY, LOBBY, and STATION.

Other Features

- User Presets
- Variable Gamma Curve
- Two Setting Modes
- DC Servo Lenses
- AC 24 V/DC 12 V operation (for SSC-G723)
AC 220 V to 240 V operation (for SSC-G728)
- Internal Lock/Line Lock
- Slow Shutter
- Digital Zoom
- Electronic Day/Night

SPECIFICATIONS

	SSC-G723	SSC-G728
Image device	1/3-type Super HAD II CCD	
Picture elements (H) x (V)	976 x 582	
Signal system	PAL standard	
Horizontal resolution	650 TV lines	
S/N	Better than 50 dB (AGC OFF)	
Auto iris lens	DC servo auto	
Digital zoom	x1/x2/x4/x6/x16	
VIDEO level	Variable	
AGC	OFF/Normal/Turbo/Manual	
Shutter	1/50 to 1/100,000 (12 steps), OFF/MANUAL/CCD-IRIS selectable	
Back-light compensation	OFF/DynaViewEX/iBLC/SPOT	
Dynamic ranges	More than 75 dB	
Minimum illumination	Color: 0.22 lx at F1.2 (50 IRE, AGC ON, Turbo mode), B/W: 0.11 lx at F1.2 (50 IRE, AGC ON, Turbo mode)	
Variable gamma	OFF/SCENE1/SCENE2/SCENE3/SCENE4 selectable	
White balance	ATW/ATW-PRO/3200K/5600K/Manual	
Sharpness	SOFT/NORMAL/SHARP	
Color saturation	L to H (4 steps)	
Electronic Day/Night	Auto/Color/B/W selectable	
Privacy masking	ON/OFF selectable (with area setting function)	
Camera title	Up to 24 characters (Alphabet, Arabic numeral and some marks), ON/OFF selectable (with 4 prepositions)	
Use presets	A/B Reset selectable	
Custom templates	ENTRANCE/OFFICE/PARKING/SUBWAY/LOBBY/STATION	
Flip	OFF/VERT/HORIZ/BOTH selectable	
Digital noise reduction	L to H (5 steps)	
Slow shutter	OFF/x2/x4/x8/x16/x32/x64/x128/x256/x512	
Back focus adjustment	YES	
Synch system	Internal/AC line lock selectable	
RS-485 address	1-255	
Operating temperature	-10 °C to +50 °C	
Storage temperature	-40 °C to +60 °C	
Operating humidity	20 to 80%	
Storage humidity	20 to 95%	
Power requirement	DC 12 V ±10% or AC 24 V 10% -40%, 50 Hz	AC 220 V-240 V ±10%, 50 Hz
Power consumption	2.5 W	3.2 W
Mass	390 g	410 g
Dimensions	63 x 57 x 129.1 mm	
Supplied accessories	Operating instructions (1), Menu operations (1), Fall-prevention wire rope (1), Screw (1), Lens mount cap (1), AC power cable (AC 220 V-240 V only)	

DIMENSIONS

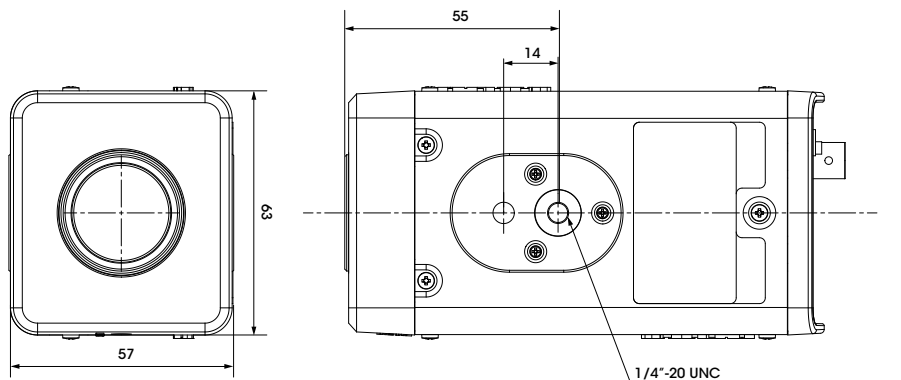

Unit: mm

REAR PANELS

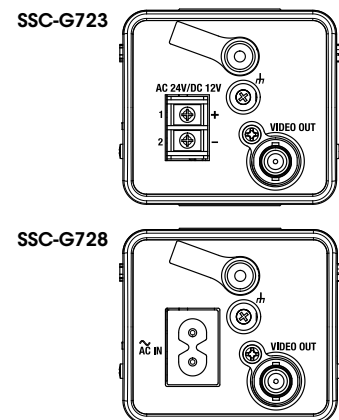

Distributed by

© 2009 Sony Corporation. All rights reserved.

Reproduction in whole or in part without written permission is prohibited. Design, features and specifications are subject to change without notice.

All non-metric weights and measures are approximate.

Sony is a registered trademark of Sony Corporation.

DynaViewEX, Super HAD CCD II is a trademark of Sony Corporation.

All other trademarks are the property of their respective owners.